



Application:

Elastomeric plastics (including L.S.R. - Liquid Silicone Rubber)

Shut-off technique:

Needle shut-off with Integrated two way pneumatic actuator

Index of contents

Chapter	Page
Description	2
Advantages	2
What speaks for Herzog	2
Tip types	3
Data sheet	4
Dimension sheet for orders or enquiries	5

Description

The pneumatically controlled nozzle type NE has a needle shut-off mechanism which stops the melt stream directly at the mold interface. Rubber, liquid silicone rubber and other elastomers can be processed without fear of premature vulcanization due to the nozzle's integrated cooling system, which uniquely regulates temperature through the entire nozzle. The nozzle can also be fitted with an interchangeable diving tip for cold channel applications.

The type NE nozzle is suitable for processing with injection pressures of up to 3,000bar and an injection rate of 500cm³. The improved design has fewer parts which make for easier cleaning and a simple installation. It has been also optimized for melt-flow which results in less friction on the processed elastomer.

It is manufactured from completely rust-free materials and is available in custom lengths.

Advantages

Prevents:

- Silicone vulcanisation in the nozzle
- Material leakage when dosing with a retracted injection unit
- Material leakage while vertically injecting

Supported process control:

- Optional piston position sensors (indicates if nozzle is "open" or "closed").

Productivity factors:

- Controlled, clean shut-off of the melt stream
- Increased process reliability and repeatability

What speaks for Herzog

- Nozzle activity is the core business
- Many years market presence
- Design and assemblies matching today's requirements
- Development of special applications
- Fast delivery
- Service performance

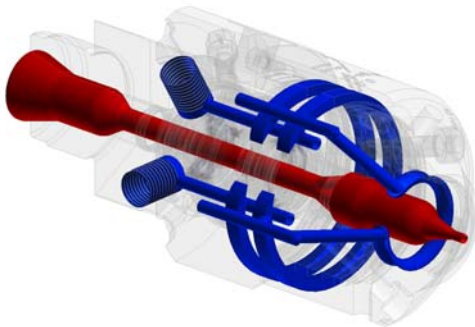

Legend

- Melt stream
- Cooling circulation

Tip types

Tip with radius or angle → nozzle arrangement with hot mold

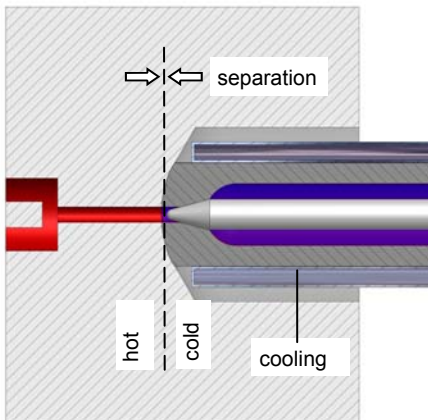

For mold plates with thermal separation between sprue bushing and nozzle. The nozzle should shut as close as possible to the cavity. Cooling through the entire immersion length is required.

Tip contour and orifice are manufactured to customer specifications.

The nozzle tip lies against the hot mold and is tempered (cooled). Premature vulcanisation is therefore eliminated. The thermal separation occurs between the mold and the cooled nozzle.

Conical tip for cold channel → nozzle arrangement with cold channel

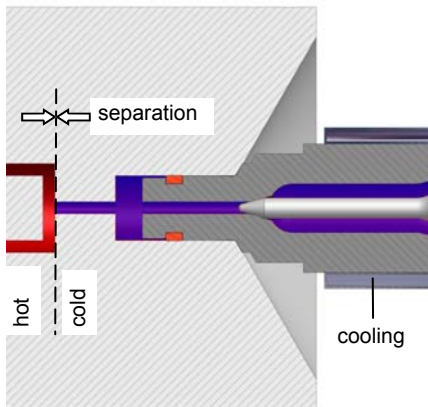

For mold plates with thermal separation between the injected part and the sprue bushing. The tip's conical contour is mostly $\varnothing 15 \times 23 \text{ } 120^\circ$ or $\varnothing 20 \times 23 \text{ } 120^\circ$.

The nozzle tip lies against the cold channel. The thermal separation occurs between the cold mold and the hot cavity.

Our NE-nozzle with cold channel tip is not designed for application with hot molds. The silicone would in this case vulcanise in the nozzle tip and block the orifice.

The conical tip is impermeable due to a sealing. A 120° conical surface resists the contact force of the injection unit. When retracting the injection unit the material in the mold is released and decompressed.

Conical tip for cold channel with radial adjustment element

→ compensates displacement of up to 2 mm

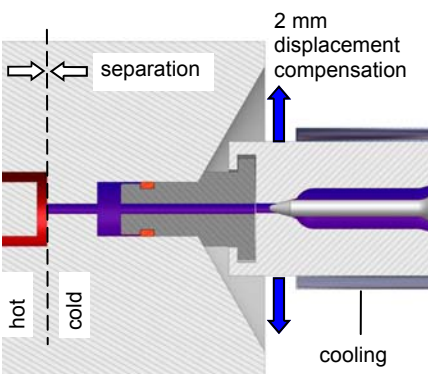

The function of the cold channel tip with radial displacement compensation is similar to the cold channel tip. The conical tip can additionally move laterally and/or equalize displacement.

Mult component processing with lateral injecting:

The lateral molding point is sensitive to the movements of the machine plate.

The tip equalization can compensate for this movement which in turn protects the nozzle from damage.

Data sheet - machine shut-off nozzle, type NE pneumatically controlled

Operating data

	NE
max. injection rate cm ³ / s	500
max. contact force (kN)	120
smallest nozzle orifice (mm) M at max. injection rate	Ø 2
max. back pressure	400 bar
max. injection pressure	3000 bar
temperature range	-20°C to 110°C

Radial or angled tip
Hot mold application

Conical tip
Cold channel application

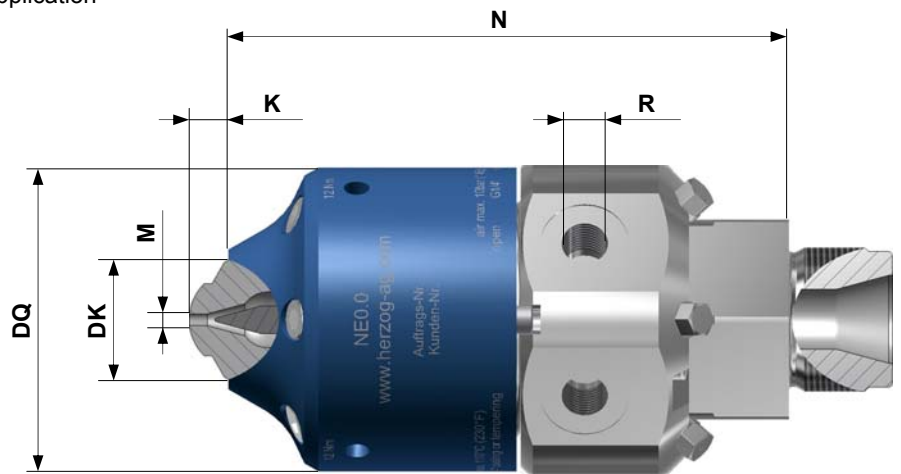
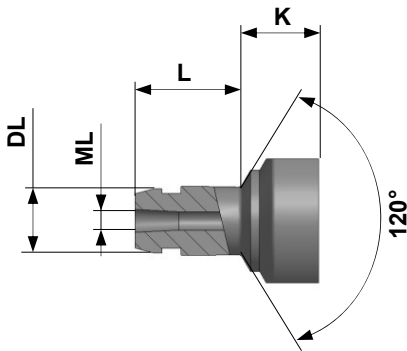

Actuation

pneumatic	4 - 10 bar
functionality	two-way

Connections

R	pneumatic connection	2 x G1/4
	connection for tempering liquid	2 x G1/4

Key Description

Standard dimensions in mm

K	tip length	from 10, other dimensions on request
DK	tip Ø	Ø 32
M	max. orifice	Ø 6
DQ	flange Ø	Ø 82
N	body length	140
L	length until separation point	23
DL	conical Ø	Ø15, Ø20
ML	conical orifice	Ø 5

Technical modifications reserved. For orders or enquiries please fill out the **Dimension sheet**.

Dimension Sheet for enquiry	or order	Machine shut-off nozzle type E, pneumatically controlled
------------------------------------	-----------------	--

Company:
Street:
City / Zip:
Land:

Contact person:
Tel.:
Fax:
E-Mail:

Machine type (when known)

If optional extras are required or when processing with the above special applications, please enter here:

★ Standard dimensions, see **Data Sheet**.
Measurements in mm

Hot mold application:

★ Tip length
(check standard dimensions)

Tip length
Orifice
Tip contour (radius or angle)



Cold channel application:

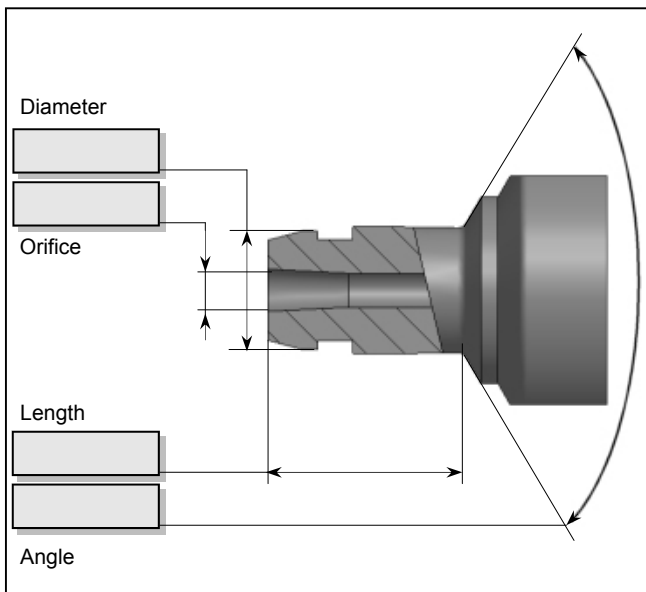

Note:
Technical modifications reserved.

We need additional information for requirements, which vary from our standard range e.g. drawing sample. Our customer services will be pleased to help you.